

# Access™ BMU

## Battery Monitoring Unit

### BMU Basic UL, WET Soldered



EN	Instruction for use .....	3
	Figures .....	9

Approvals .....	10
-----------------	----



# Access™ BMU - Instruction for use

## General

Access™ BMU is designed for monitoring vented lead-acid batteries. The unit is mounted on the battery and monitors voltage, temperature and electrolyte level.

The functions in Access™ BMU are activated, deactivated and adapted using the PC software Access™ Service tool.

Access™ BMU is permanently mounted on the battery or used as a temporary instrument for troubleshooting or operating analysis.

When using Access™ BMU together with the Access™ battery charger, the battery charger is sent battery specific parameters from the battery monitoring unit for optimal charging of the battery. The status of the battery can be read on the charger's display.

Information about the charging and discharging process, the battery status and deviations are stored internally in the unit. Access™ BMU communicates wirelessly with other Access™ units.

Information concerning the product's part number, serial number and rating can be found on the rear of the unit.

## Safety

### Warning information

Hazardous situations and precautionary measures are presented in the text as set out below.

#### Warning

Situations that may result in severe personal injury or death if the instructions are not followed.

#### Caution

Situations that may result in personal injury or damage to the product if the instructions are not followed.

### Note:

Information that is important without being related to safety.

## General



Always keep the manual in the vicinity of the product.

The manual contains important information about safety and user instructions.

Read and understand these instructions, the instructions supplied by the battery manufacturer with the battery and the employer's safety instructions before the product is used, installed or serviced.

Only qualified personnel may install, use or service this product.

## ELECTRIC SHOCK



The battery may contain voltage on a level that may cause personal injury.

#### Warning

Do not touch uninsulated battery terminals, connections or other live parts.

## EXPLOSIVE GASES



Hydrogen gas is produced when charging lead acid batteries; this can cause an explosion.



Do not smoke, cause sparks or use an open flame in the vicinity of batteries.

## **⚠ Warning**

Risk of explosion!

Do not smoke, cause sparks or use a naked flame in the vicinity of batteries.

Arcing can injure the operator or damage the battery connector.

Ensure that the charging parameters have been set correctly according to the battery manufacturer's specification.

Do not use the battery if the battery monitoring unit or its cabling are damaged.

Use insulated tools designed for working on batteries.



Only perform charging in a well ventilated environment.

2. Indication of low electrolyte level (red)
3. Indication for the specified time and date (green)
4. Indication of the network status (green)
5. Not used.
6. Magnetic switch network management

### **Battery, cross section**

See Fig. 3

1. Seal, electrolyte level and battery temperature sensor
2. Lead probe, electrolyte level and battery temperature sensor
3. Electrolyte
4. Lead plate, battery

## **Acceptance**

On delivery, visually check the unit for signs of physical damage.

Check that delivered parts correspond with the consignment note. Contact your supplier if anything is missing, see *Contact information*.

## **Description**

### **Access™ BMU installed on the battery**

See Fig. 1

1. Positive terminal, battery
2. Cable (red) for powering Access™ BMU and for the supply of battery voltage
3. Electrolyte level and battery temperature sensor (black)
4. Access™ BMU
5. Cable (black), negative terminal for powering Access BMU and for the supply of battery voltage
6. Negative terminal, battery

### **Access™ BMU**

See Fig. 2

1. Indication of high battery temperature (red)

## **Installation**

### **⚠ Warning**

Electrolyte is corrosive!

If electrolyte comes into contact with the eye, damage can occur very quickly.

Rinse the eye immediately and thoroughly for at least 10 minutes, seek medical attention.

Wear protective equipment such as safety glasses and gloves to avoid contact with the electrolyte.

### **Note:**

*Installation may only be performed by qualified installers.*

Follow the battery supplier's instructions for handling batteries.

Access™ BMU is solely designed for use with lead-acid batteries up to 96 V nominal DC voltage. Consult the manufacturer regarding all other usage.

Ensure that the Access™ BMU is installed by a qualified installer in accordance with the instructions.

Access™ BMU must be well protected against mechanical damage during daily use, servicing and maintenance.

# Instructions

A threaded insert must be installed to connect Access™ BMU on the lead terminals of the battery and cells.

## Installation of the threaded inserts

1. Drill a 5.5 mm (0.219 inch) hole in the appropriate lead terminal. The depth of the hole must be at least 7.7 mm (0.302 inch).
2. Knock the supplied threaded insert into the hole.

Now secure the cable lug, use the supplied washers and screws.

## Installation of BMU

1. Installation of Access™ BMU (Fig. 1):
  - Install the battery monitoring unit and its cables in a dry place on the battery.
  - Make sure there is no risk of mechanical damage.
  - The battery monitoring unit is installed so the control panel is fully visible.
2. Connect the battery monitoring unit's black cable (Fig. 1 pos 5) to the battery's negative terminal (Fig. 1 pos 6).
3. Locate where the electrolyte level and battery temperature sensor is to be installed.

### Note:

*This sensor may only be used on vented batteries.*

The electrolyte level and battery temperature sensor (Fig. 1 pos 3) must be installed at least 3 cells from the battery's negative sensor in order for the sensor to work correctly.

4. Drill a 12 mm (0.472 inch) hole in the top of the battery cell for the electrolyte level and battery temperature sensor.
5. Fit the sensor's seal (Fig. 3 pos 1).
6. Cut the sensor's lead probe (Fig. 3 pos 2) and the plastic casing so that the sensor gives an alarm well in advance of the water reaching a critical level for the battery. The cut must be diagonal so that there is a sharp pouring edge.

If the electrolyte level is (Fig. 3 pos 3) below the lead probe the low electrolyte level indicator

comes on 

The battery's lead plates (Fig. 3 pos 4) must be covered with electrolyte.

### ⚠ Warning

Risk of short-circuiting!

High voltage!

Make sure that the electrolyte level and battery temperature sensor is not in contact with the battery's lead plates. This can result in short-circuiting and incorrect status indication.

7. Install the electrolyte level and battery temperature sensor. Makes sure the seal closes tightly against the hole.
8. Connect the battery monitoring unit's red cable (Fig. 1 pos 2) to the battery's positive terminal (Fig. 1 pos 1).

All indications on the battery monitoring unit's control panel come on briefly.
9. Check and rectify any indications. Indications are described in *Status indicator*.
10. Secure Access™ BMU and its cables using the supplied cable ties.
11. Check that all the battery's soldered joints are correct.

### ⚠ Warning

Risk of fire!

A poorly soldered joint can damage the battery, resulting in heat development and fire.

Check all soldered joints.

## Connecting to a network

On delivery, Access™ BMU is connected to a factory set network.

The charging parameters and other settings in Access™ BMU must be set correctly for the battery in question.

The settings are made with the Access™ Service tool, which must be connected to the appropriate Access™ BMU.

Some settings for Access™ BMU can also be made using the menu system on the Access™ battery charger when they are connected to each other.

## ⚠ Caution

Incorrectly set charging parameters can damage the battery.

### Connect to the existing network with the associated Access™ Battery charger

1. Set the charger's charging parameter **Source** in the menu **Service/Charging parameter to BMU** or another BMU option.
2. Activate **Join enable** on the charger.
3. Connect the charger to the battery that has the relevant Access™ BMU fitted.
4. If charging starts within 1 minute the Access™ BMU has succeeded in connecting to the network.  
Battery ID is shown on Access™ the battery charger's display.

### Connect to an existing (not factory set) network only with other Access™ BMU units

The Access™ BMU that is to be connected to the network must be reset to the factory set network. This is to make **Activate connection** possible. See *Resetting the factory set network*.

In order to activate **Join enable** on the Access™ BMU that is connected to the correct network:

1. Hold a strong magnet over the magnetic switch .

The network status indicator  starts to flash and the unit has **Join enable** activated.

In order for **Activate connection** on the Access™ BMU to be connected on the network:

2. Hold a strong magnet over the magnetic switch .

The network status indicator  starts to flash and the unit searches for and connects to the network that has **Join enable** activated.

### Connect new Access™ BMU units to the factory set network

New Access BMU units connect directly to the factory set network during installation.

### Start and connect to the new specific network with the Access™ Service tool

The Access™ BMU that is to be connected to the network must be reset to the factory set network. This is to make **Activate connection** possible. See *Resetting the factory set network*.

1. Start the Access™ Service tool.
2. Select **Start a network**.
3. Activate **Join enable**.

In order for **Activate connection** on the Access™ BMU to be connected on the network:

4. Hold a strong magnet over the magnetic switch .

The network status indicator  starts to flash and the unit searches for and connects to the network that has **Join enable** activated.

5. A new network has now been started where only the current Access™ BMU and Access™ Service tool are connected. Additional units can be added to this network.

### Resetting the factory set network.

1. Hold a strong magnet over the magnetic switch  on the battery monitoring unit's control panel.









The network status indicator  starts flashing.

2. Hold the magnet over the magnetic switch and restart the battery monitoring unit by loosening and then connecting the red cable (Fig. 1 pos 2) from the battery's positive terminal.
3. Take away the magnet.
4. Access™ BMU is now reset to the factory set network.

## Status indicator

### Status indicator on the control panel.

See Access™ BMU.

Indication	Status	Cause	Action
	Flashes	The battery is too warm.	<p>a. Allow the battery to cool.</p> <p>b. Reduce the workload on the battery.</p> <p>c. In Access™ Service tool, check that the battery's temperature level for alarm indication corresponds with the battery manufacturer's recommendation. If necessary, adjust the temperature level.</p>
	Flashes	<p>a. Low electrolyte level.</p> <p>b. The electrolyte level and battery temperature sensor is installed incorrectly.</p>	<p>a. Top up the battery water.</p> <p>b. Check the installation of the electrolyte level and battery temperature sensor, see <i>Installation</i> step 3.</p>
		Not used.	
	Flashes	Time and date set incorrectly.	Set the time and date with the Access™ Service tool.
	Lit	Time and date are set correctly, unit works.	
	Flashes	The battery monitoring unit is searching for a network to connect to or has connection permitted enabled.	Take away the magnet from the magnetic switch.
	Lit	The unit is connected to a network.	
All indicators flashing		An identification request has been sent from the Access™ Service tool.	The indicators go out automatically after the requested identification time has elapsed, normally 10 seconds.
No indicators lit		No supply voltage.	<p>Check the battery monitoring unit's connections to the battery's positive terminal.</p> <p>Check the fuse on the cable between the battery monitoring unit and the battery's positive terminal.</p>
  	These are lit, the others are off.	Software in Access™ BMU is being updated.	Wait until Access™ BMU starts up, this normally takes 15-30 seconds. Do not disconnect the supply voltage.

## Operation

### Measurement values and events

Measurement values and events are stored during operations for service and analysis purposes.

The structure of this information is described in the Technical Manual for Access™ BMU. The information is read using the PC software Access™ Service tool.

## Maintenance

### ⚠ Caution

Maintenance may only be performed by qualified service personnel.

### ⚠ Warning

Risk of corrosive damage!

Batteries contain corrosive electrolyte.

Use requisite protective clothing when working on batteries.

### ⚠ Warning

Risk of high voltage!

Do not use the battery if the battery monitoring unit or its cabling are damaged.

Do not touch uninsulated battery terminals, connections or other live parts.

Contact a service technician.

### ⚠ Warning

Access™ BMU must not be cleaned with a high pressure washer.

1. Check that the battery monitoring unit's cables are free of faults, in good condition and show no signs of mechanical damage.
2. Check and rectify any indications on the battery unit's control panel.
3. Check that the battery monitoring unit and its cables are secured firmly on the battery.
4. Check that there is no grime or battery acid on the Access™ BMU. Clean if necessary.

## Recycling

The product is recycled as electronic waste. Local regulations apply and must be followed.

## Contact information

Micropower E.D. Marketing AB  
 Idavägen 1, SE-352 46 Växjö, Sweden  
 Phone: +46 (0)470-727400  
 e-mail: support@micropower.se  
 www.micropower-group.com



# Figures

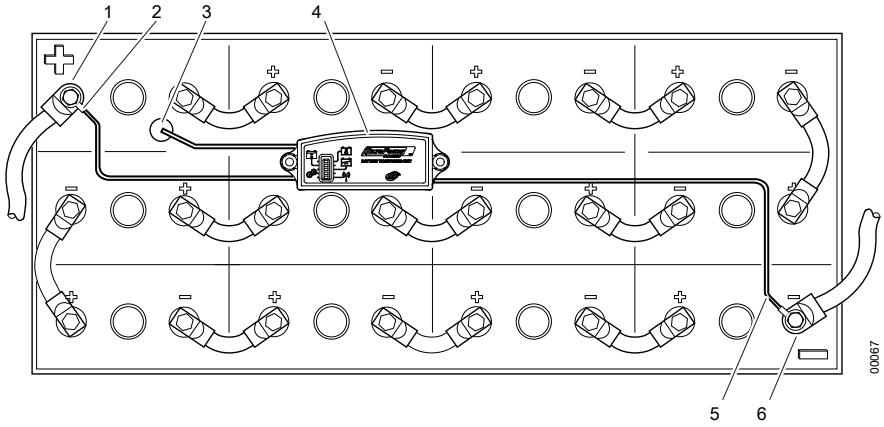

Fig. 1 Access™ BMU installed on the battery

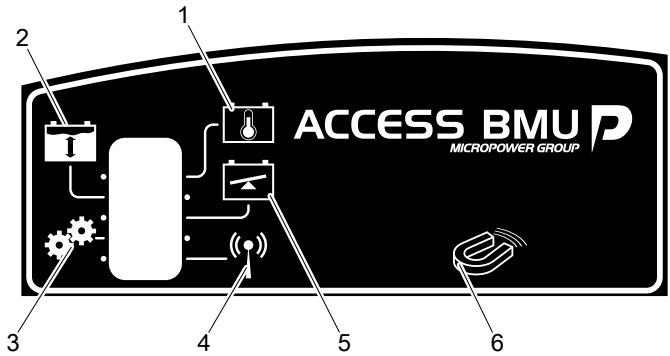

Fig. 2 Access™ BMU

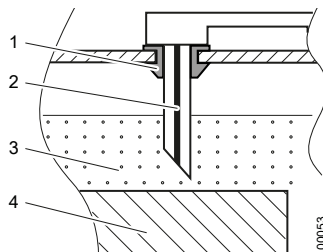

Fig. 3 Battery, cross section

# Approvals

## FCC/IC information

The product is FCC/IC registered and contains FCC ID: B7WACCESS, IC: 10687A-ACCESS.

### **Warning**

---

Changes/modifications not approved by the responsible party could void the user's authority to operate the equipment. This transmitter must not be relocated or operated in conjunction with any other antenna or transmitter. This equipment complies with FCC and IC radiation exposure limits set forth for an uncontrolled environment. This equipment should be installed and operated keeping the radiator at least 20 cm or more away from person's body (excluding extremities: hands, wrists, feet and ankles).

---

### **Avertissement**

---

Les changements/modifications non approuvés par le parti responsable pourraient invalider l'autorité de l'utilisateur à faire fonctionner l'équipement. Cet émetteur ne doit pas être relocalisé ou être utilisé avec une autre antenne ou émetteur. Cet équipement est conforme aux limites d'exposition de émissions de IC, FCC réésentées pour un environnement non contrôlé. Cet équipement devrait être installé de façon à ce que l'antenne soit éloigné de 20 centimètres ou plus du corps humain (en excluant les extrémités : les mains, les poignets, les pieds et les chevilles).

---

# Declaration of conformity

## DECLARATION OF CONFORMITY

According to the Machinery Directive 2006/42/EC, EMC Directive 2004/108/EG, R&TTE Directive 1999/5/EC, RoHS Directive 2011/65/EU and CE Marking Directive 93/68/EEC

### Type of equipment

Battery monitoring unit.

### Brand name

MP Access BMU, MP Access BMU Basic, MP Access BLU

### Manufacturer

MICROPOWER AB, Idavägen 1, S-352 46 VÄXJÖ SWEDEN,  
Tel +46(0)470-727400, FAX +46(0)470-727401

The following standards and/or technical specifications have been applied:

### EMC - Standard

EN 61000-6-2	Electromagnetic compatibility (EMC) - Part 6-2: Generic standards - Immunity for industrial environments.
EN 61000-6-3	Electromagnetic compatibility (EMC) - Part 6-3: Generic standards - Emission standard for residential, commercial and light-industrial environments.

### R&TTE - Standard

ETSIEN 301489-1	Electromagnetic compatibility and Radio spectrum Matters (EMR); ElectroMagnetic Compatibility (EMC) and standard for radio equipment and services - Part 1: Common technical requirements.
ETSIEN 301489-3	Electromagnetic compatibility and Radio spectrum Matters (EMR); ElectroMagnetic Compatibility (EMC) and standard for radio equipment and services - Part 3: Specific conditions for Short-Range Devices (SRD) operating on frequencies between 9 kHz and 40 GHz.
ETSIEN 300440-1	Electromagnetic compatibility and Radio spectrum Matters (EMR); Short range devices; Radio equipment to be used in the 1 GHz to 40 GHz frequency range; - Part 1: Technical characteristics and test methods.
ETSIEN 3004402	Electromagnetic compatibility and Radio spectrum Matters (EMR); Short range devices; Radio equipment to be used in the 1 GHz to 40 GHz frequency range; - Part 2: Harmonized EN covering the essential requirements of article 3.2 of the R&TTE Directive.

### Machinery - Standard

EN 60 204-1	Safety of machinery - Electrical equipment of machines - Part 1: General requirements
-------------	---

As manufacturer we declare under our sole responsibility that the equipment fulfils essential requirements for CE conformity according to directive Machinery 2006/42/EC, EMC 2004/108/EG, RoHS 2011/65/EU (except the electrolyte level sensor made from lead, that should be treated as hazardous material), CE 93/68/EEC at the date of issue of the declaration.

**Date**  
2015-10-19

**Signature**  
  
Henrik Litsin

**Position**  
R&D manager